

High-Temperature Waste Heat Utilization: *Towards Flame-Temperature Topping Cycles*

Addison Killean Stark
Fellow

February 27th, 2017



Coal-Air: 2150°C

NG-Air: 1950°C

Coal/NG-Oxygen: 3000°C

SOA Heat Engines

Steam-Rankine

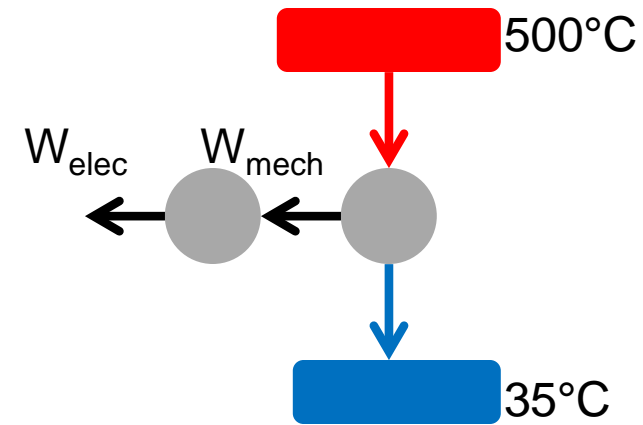

Around 40% Efficient in best cases

Air-Brayton

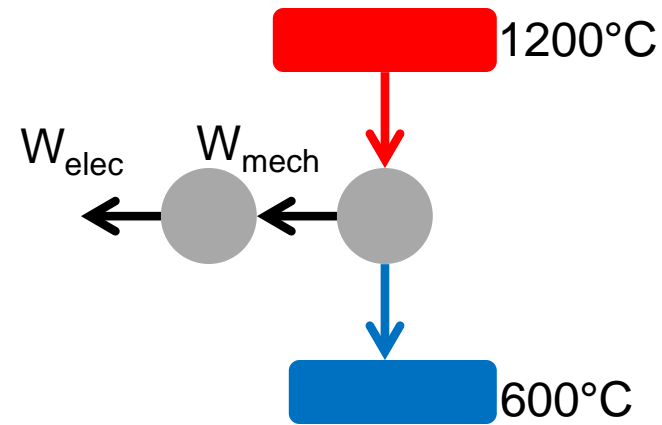

50-60% Efficient

Combined Cycle

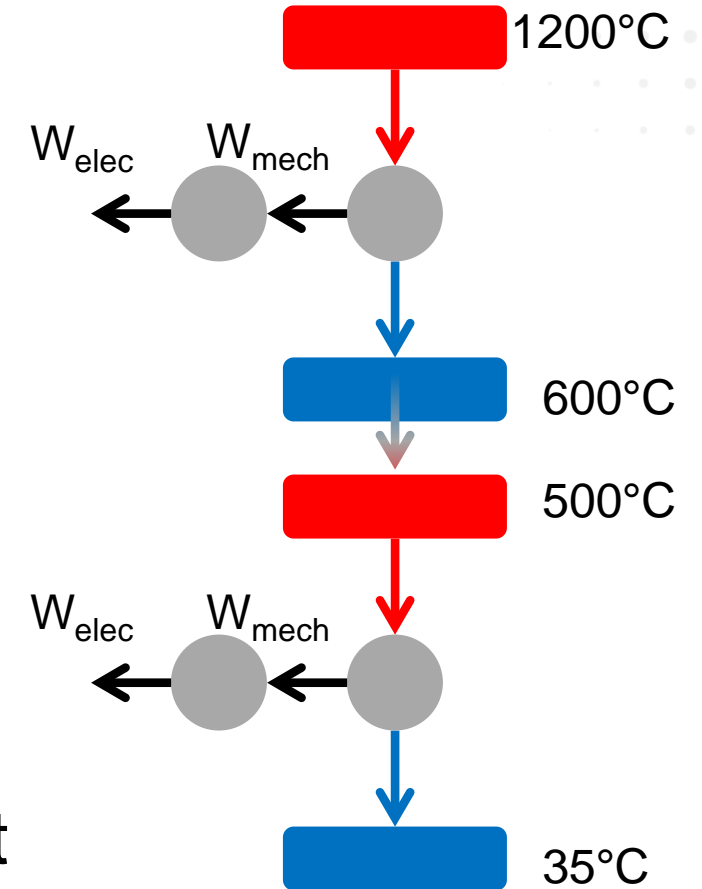

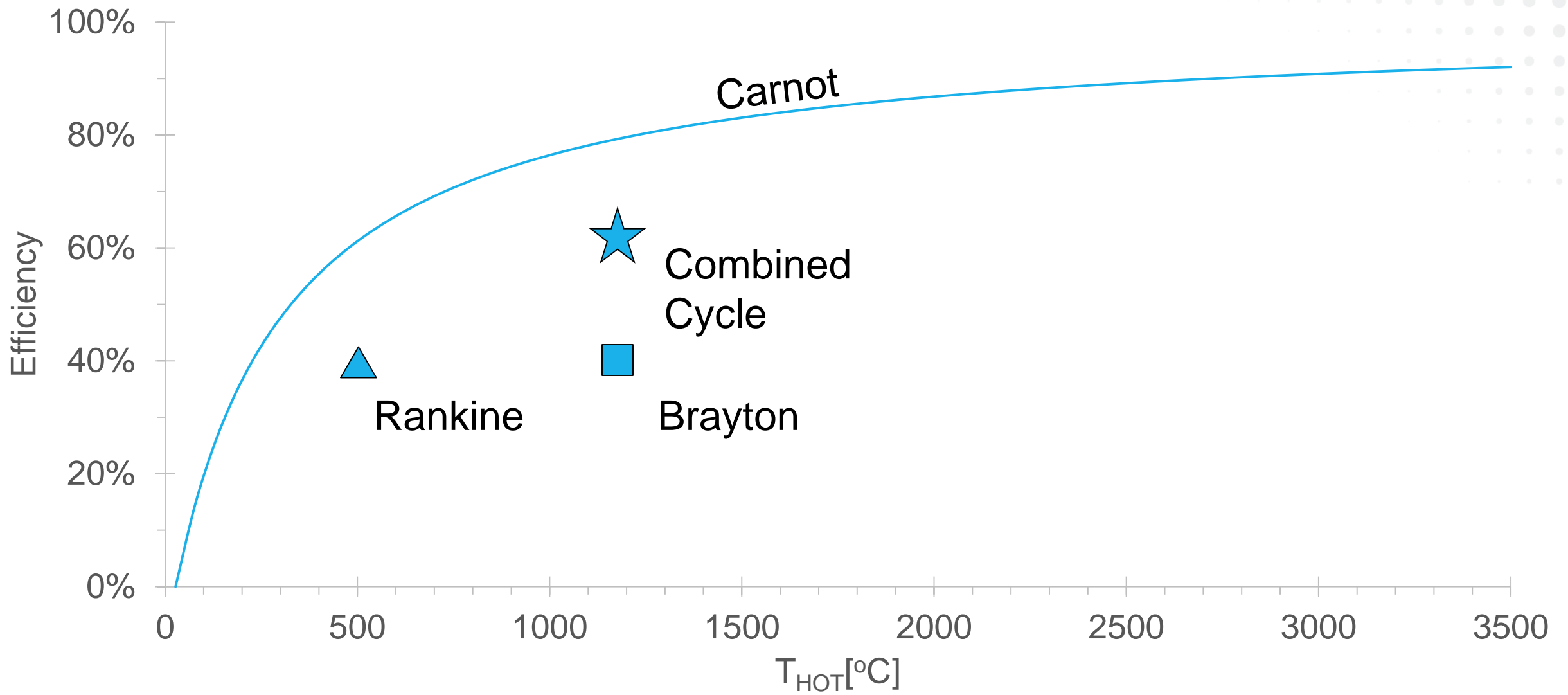

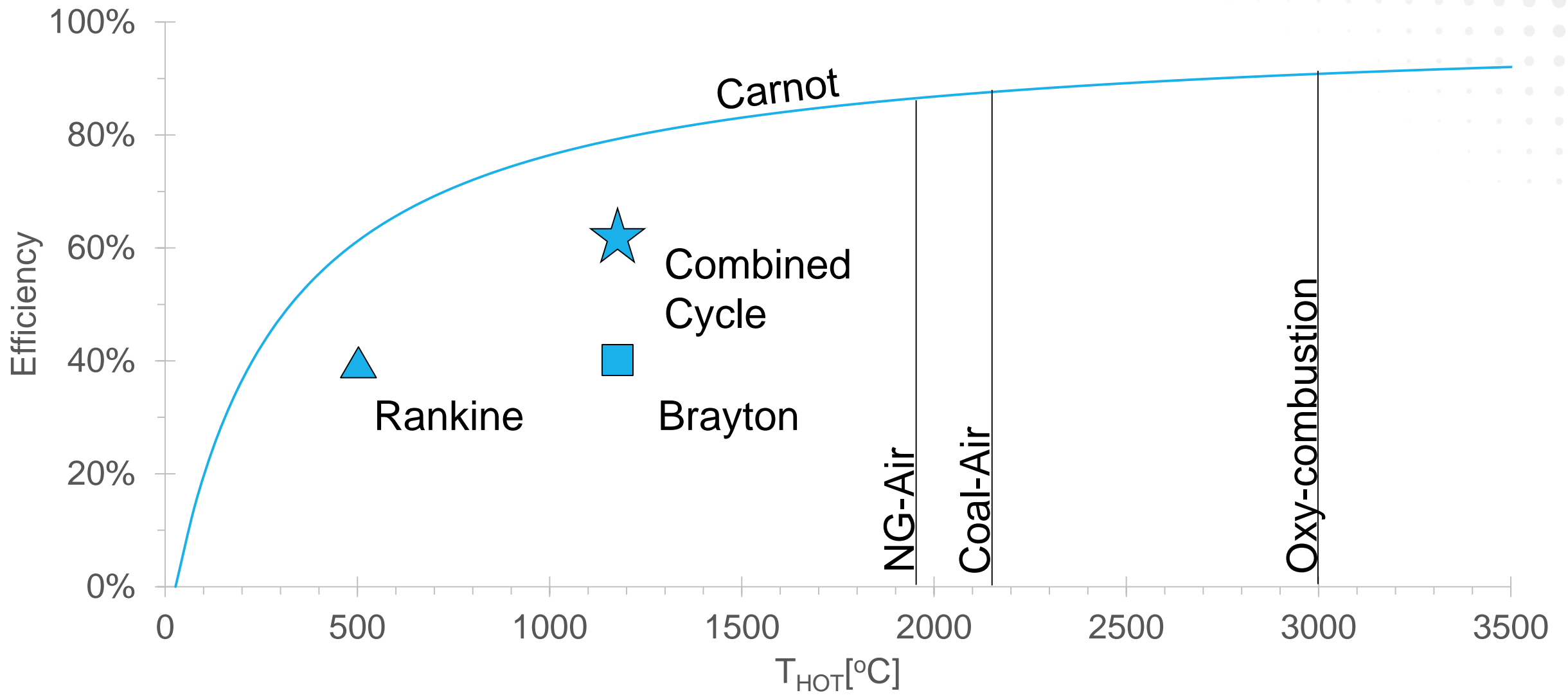

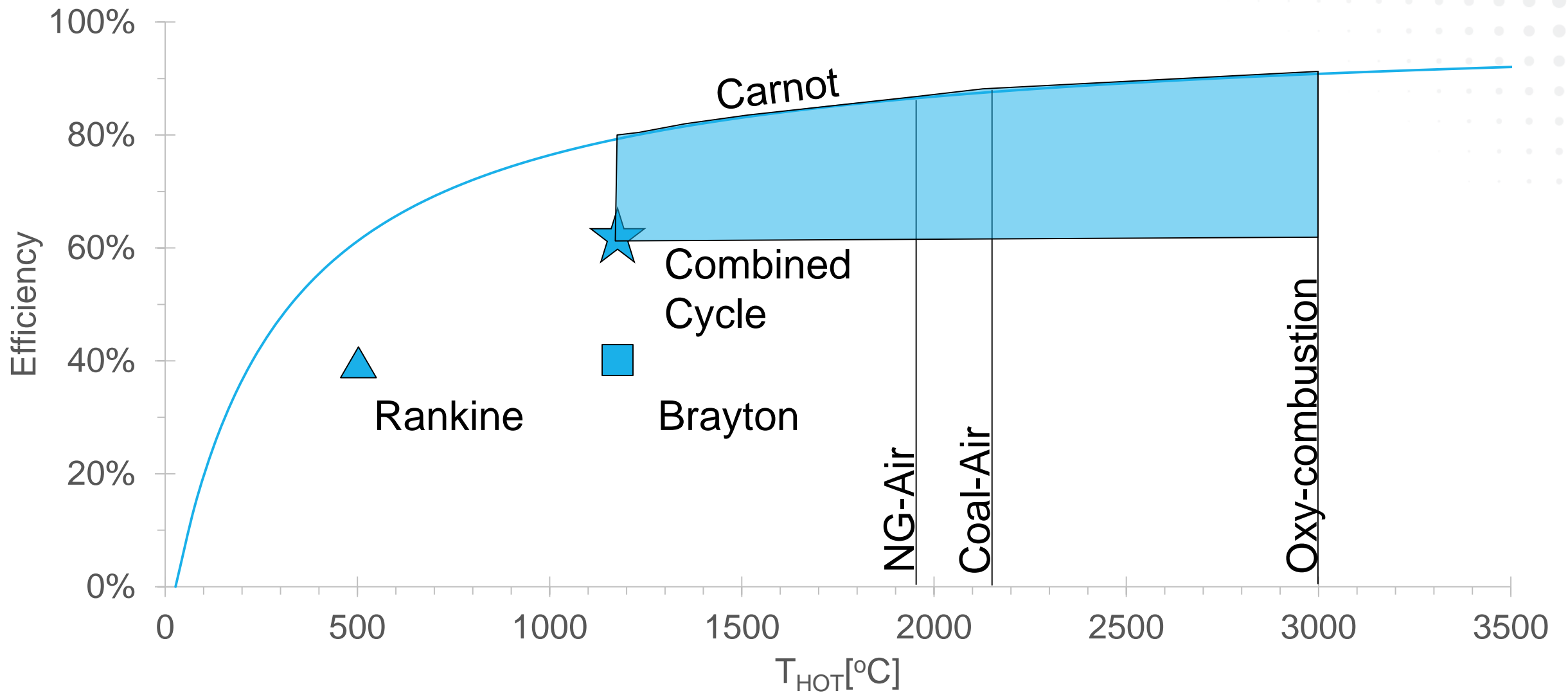

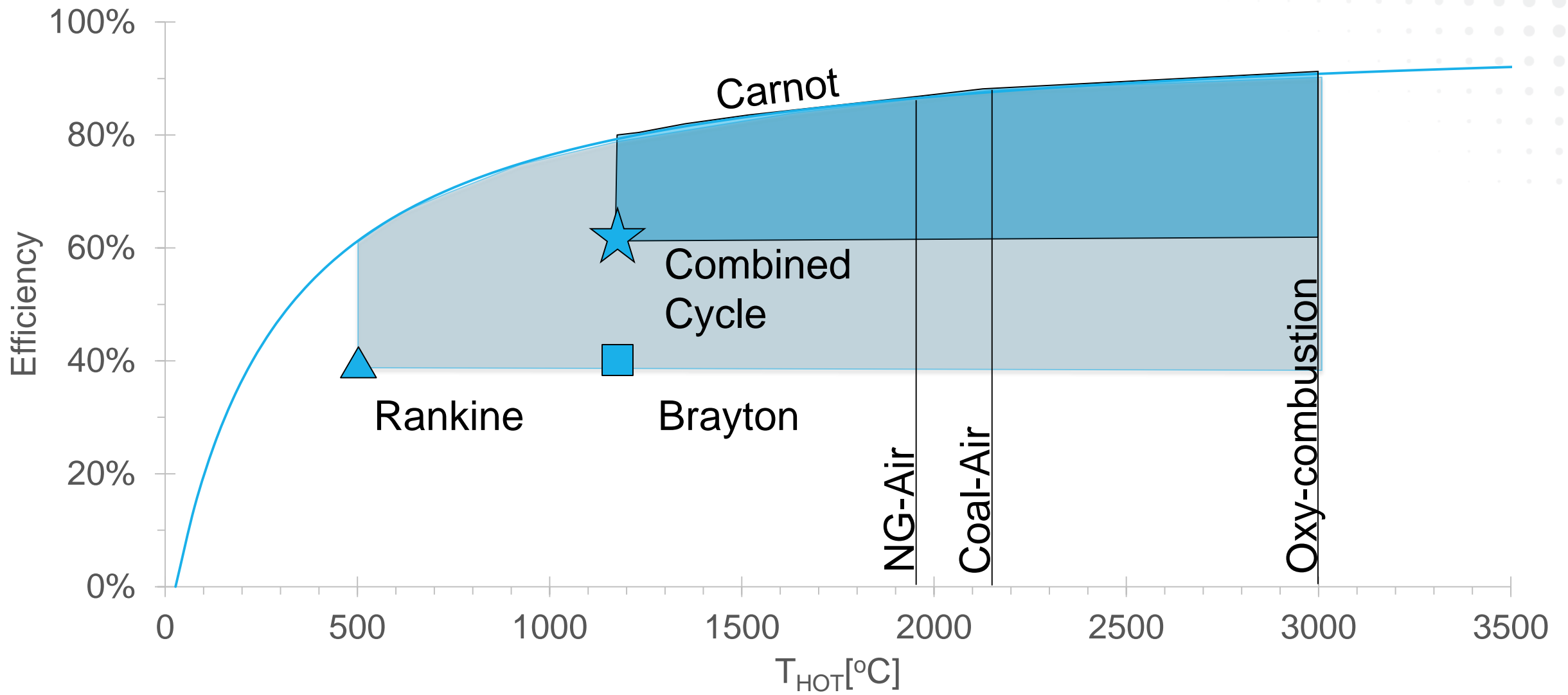

Towards a new Flame Temperature Topping Cycle

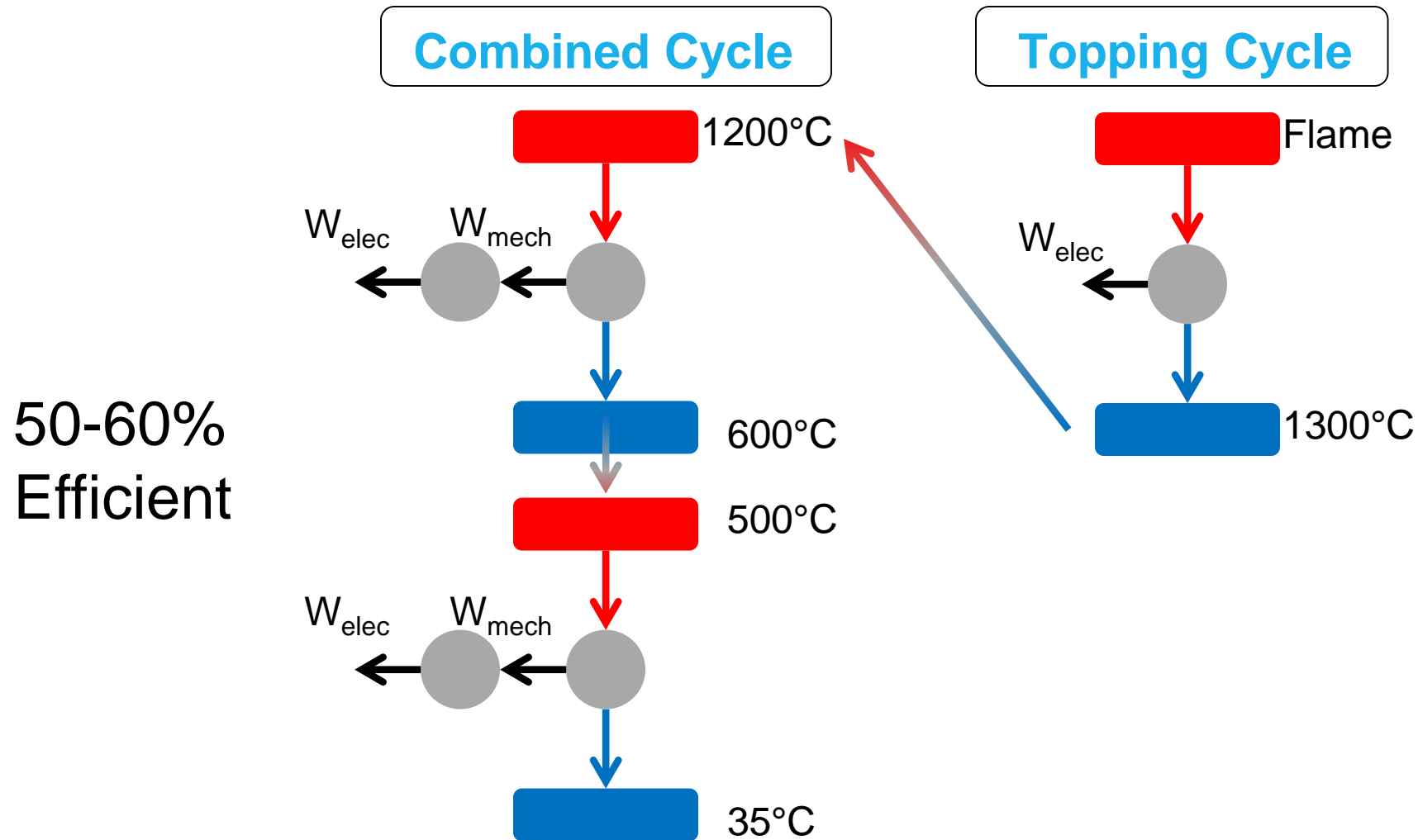

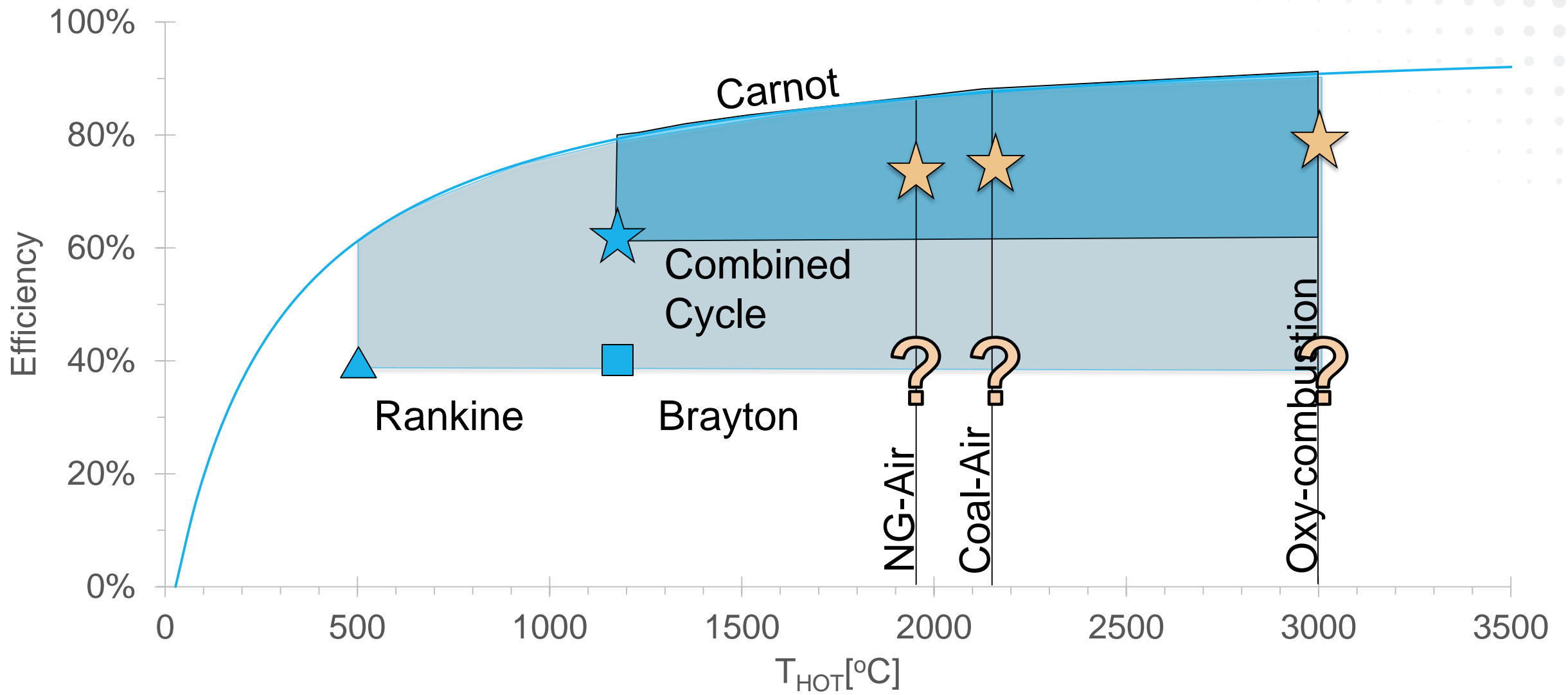

What Can Get Us There?



High T Materials

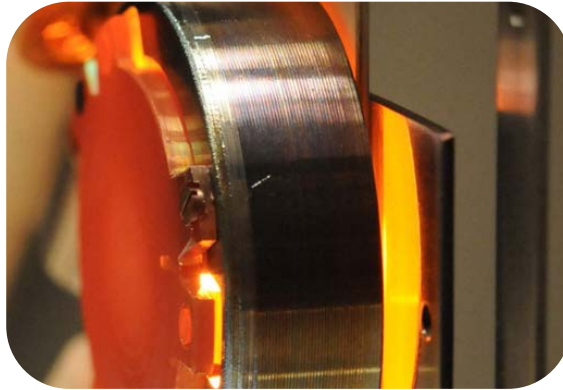

Novel Heat Engines

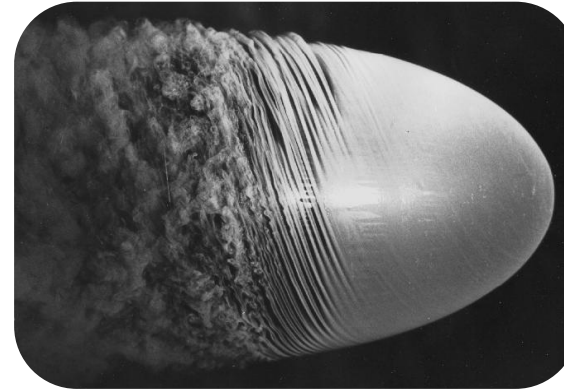

Thermal
Management

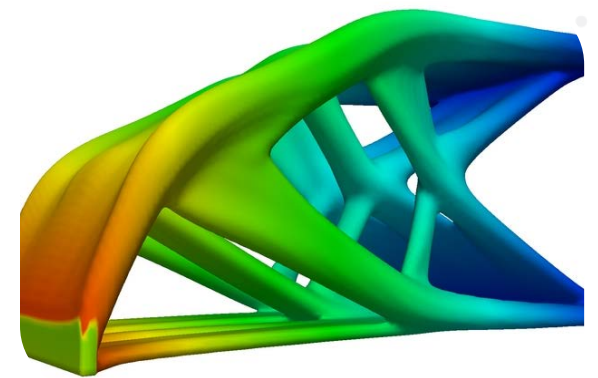

Topology &
Geometry
Optimization

Novel Heat Engines

Magneto-Hydrodynamic Generators

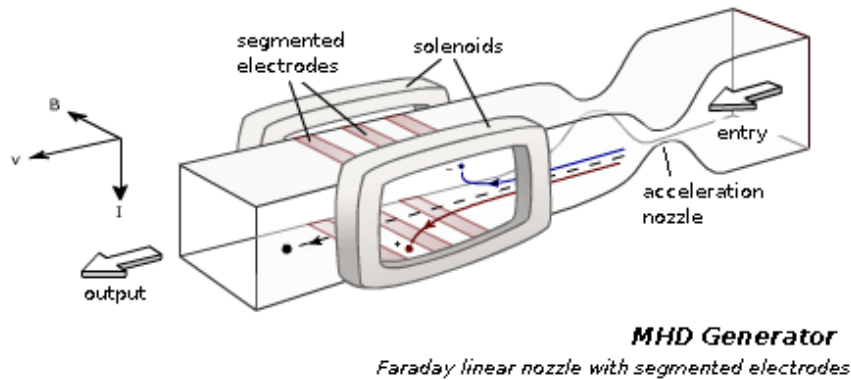
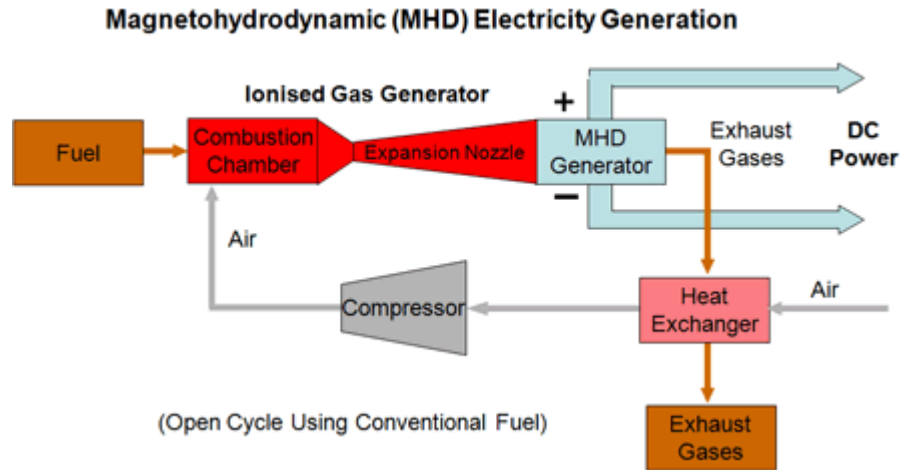

High-Temperature Ejectors

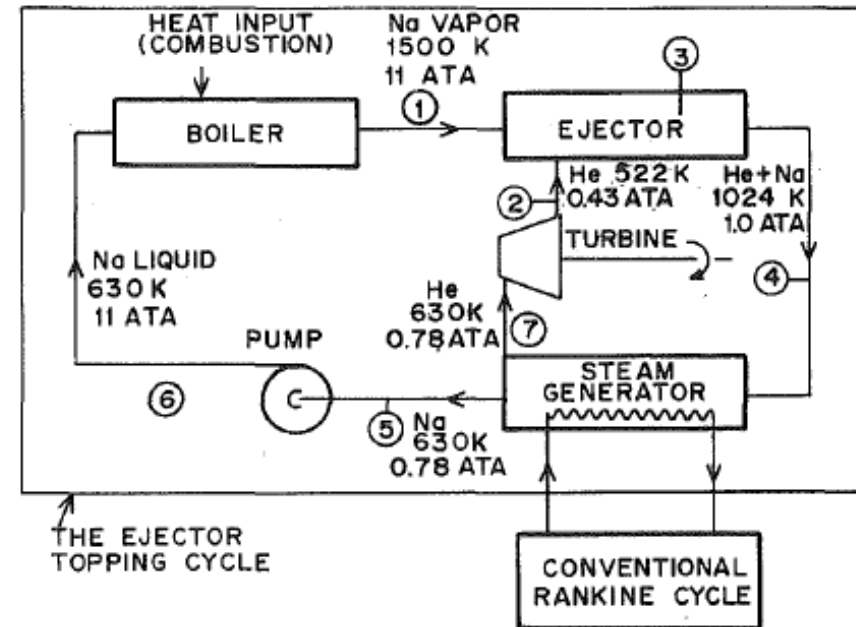

Novel Engineering

Enhanced Cooling

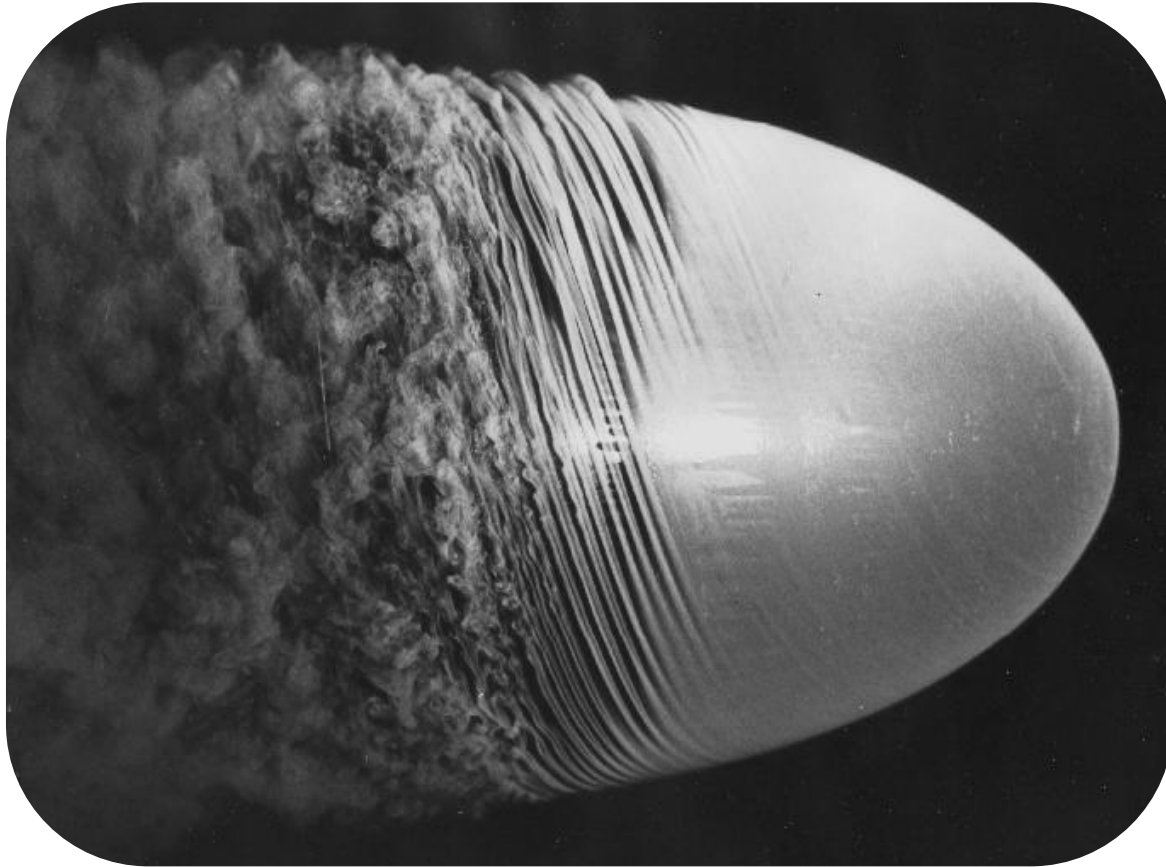

Topology and Geometry Optimization

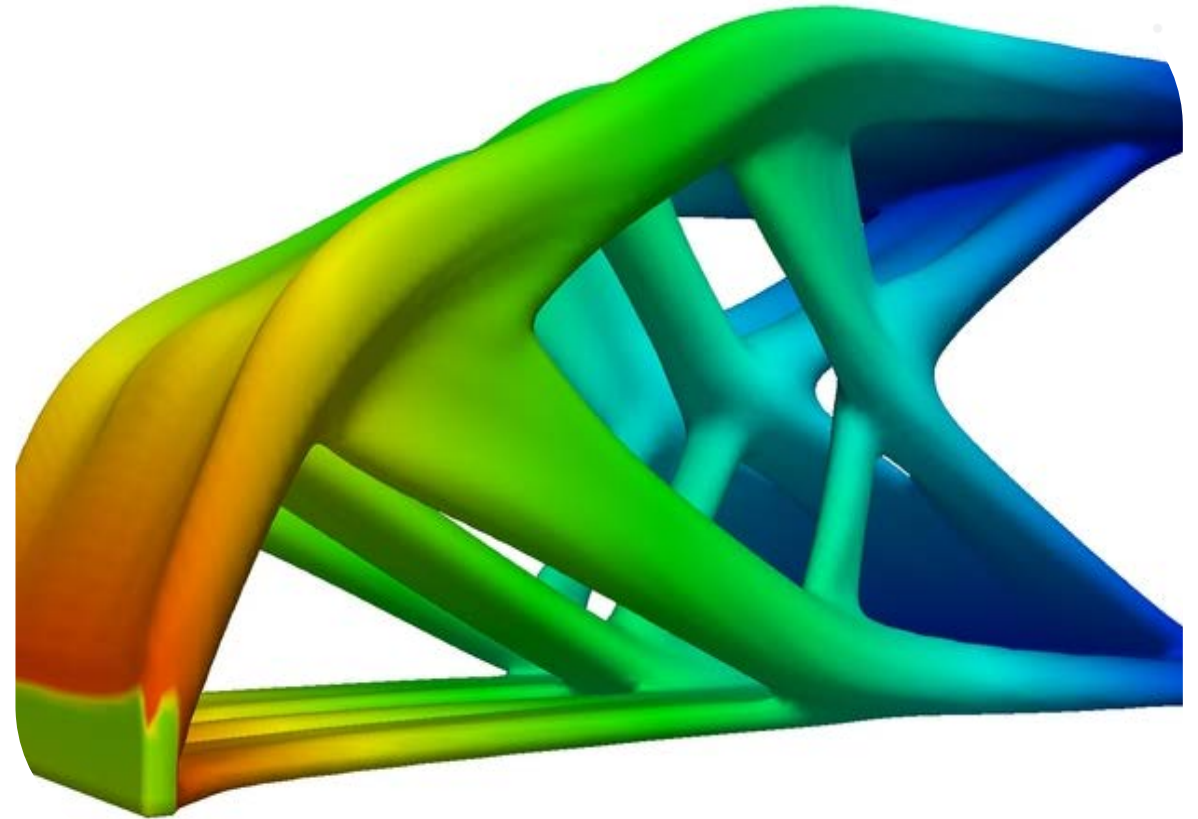



Thank You.

Addison.Stark@hq.doe.gov